

# No.61 Stop Ends

## Scope of Use / Specification Sheet

SharkBite® plumbing fittings and pipe are manufactured in Australia at RWC's state of the art facilities. Stringent quality control and advanced manufacturing procedures guarantee product satisfaction.

SharkBite® is an advanced design push-to-connect plumbing system for potable water distribution. SharkBite® is available in an assortment of over 200 fittings and PEX pipe ranging from 16-25mm size. SharkBite® has been engineered with ease of use and disconnection in mind and while being the most dependable way to join copper and PEX Pipe in any combination – with no soldering, clamps, unions or glue.



RA514X

### Features and Benefits

- Quick and easy to install in both wet or dry conditions
- No expensive tools required - supplied ready for installation
- Approved for behind the wall application
- Approved for underground installation with SharkBite Silicone Wrap (F708)
- Instant push-to-connect connection. Cut. Push. Done.
- Removable after installation
- Integral tube liner for PEX installations means no loose components and ensures a secure reliable connection

### Product List

Order Code	Description
RA514X	DN15mm Cap
RA518X	DN20mm Cap
F520X	25mm Cap (Suits PEX or Copper)

### Materials

Body	LF DZR Brass
Grab Ring	316 Stainless Steel
O-Ring	EPDM
Tube Liner	Polysulfone (PEX Fittings only)

**25** YEAR  
GUARANTEE

All SharkBite fittings are guaranteed against defects in materials or manufacturing for a period of 25 years from the date of purchase.

## No.61 Stop Ends

### Model Dimensions

Code	End Size 1	Weight	L
RA514X	DN15Cu	30 g	29
RA518X	DN20Cu	58 g	34

Note: All measurements in mm unless otherwise stated.

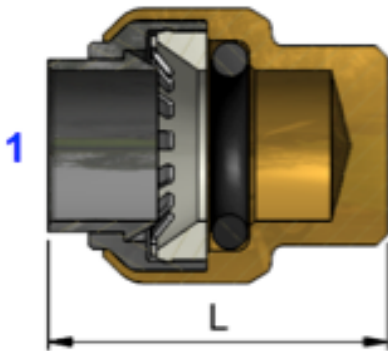

### Product Dimensions

Code	End Size 1	Weight	L
F520X	25mm OD (DN25Cu)	144 g	35

Note: All measurements in mm unless otherwise stated.

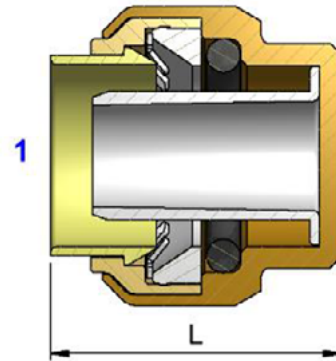

### Installation

Installation is subject to the requirements of the applicable regulatory authority, the National Construction Code Volume Three – Plumbing Code of Australia, associated reference standards as applicable at the time and AS/NZS 3500. This product is compliant to the Lead Free requirements of the National Construction Code Volume Three. For further Scope of Use, please visit [www.rmc.com.au/resources](http://www.rmc.com.au/resources).

### Warranty

Reliance Worldwide Corporation (Aust.) Pty. Ltd. (RWC) will either replace or repair any defective goods where the defect arose as a result of manufacture within the warranty period. You may contact RWC at the phone number, address or e-mail shown below for further information or to make a claim.

Visit [www.rmc.com.au/warranty](http://www.rmc.com.au/warranty) to view the warranty statement in full and for further important information.

### Standards and Approvals



Lead Free

AS/NZS 4020, AS/NZS 2537.2  
AS 2492 & AS 3688