

# Ball Valves

## Scope of Use / Specification Sheet

SharkBite® plumbing fittings and pipe are manufactured in Australia at RWC's state of the art facilities. Stringent quality control and advanced manufacturing procedures guarantee product satisfaction.

SharkBite® is an advanced design push-to-connect plumbing system for potable water distribution. SharkBite® is available in an assortment of over 200 fittings and PEX pipe ranging from 16-25mm size. SharkBite® has been engineered with ease of use and disconnection in mind and while being the most dependable way to join copper and PEX Pipe in any combination – with no soldering, clamps, unions or glue.

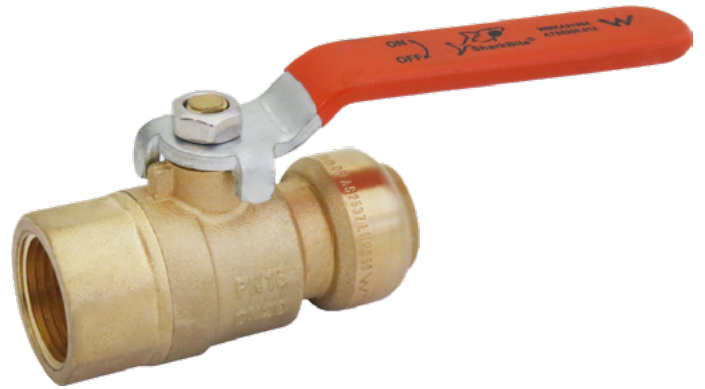

F680X

### Features and Benefits

- Quick and easy to install in both wet or dry conditions
- No expensive tools required - supplied ready for installation
- Approved for behind the wall application
- Instant push-to-connect connection. Cut. Push. Done.
- Removable after installation
- Intergral tube liner for PEX installations means no loose components and ensures a secure reliable connection

### Product List

Order Code	Description
F670X	16mm x 16mm
F672X	20mm x 20mm
F674X	25mm (DN25Cu) x 25mm (DN25Cu)
F680X	16mm x 1/2" FI
F682X	20mm x 3/4" FI
F684X	25mm (DN25Cu) x 1" FI

### Materials

Body	LF DZR Brass
Grab Ring	316 Stainless Steel
O-Ring	EPDM
Tube Liner	Polysulfone (PEX fittings only)

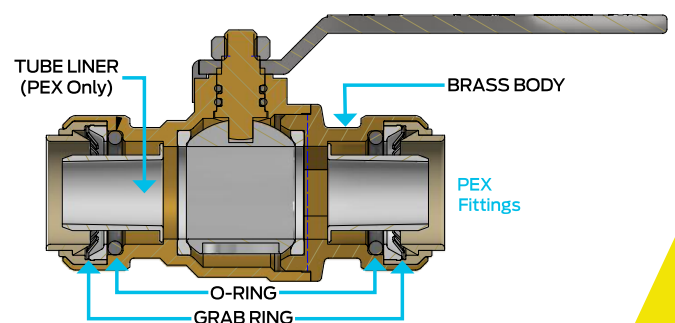

**25** YEAR  
GUARANTEE

All SharkBite fittings are guaranteed against defects in materials or manufacturing for a period of 25 years from the date of purchase.

# Ball Valves

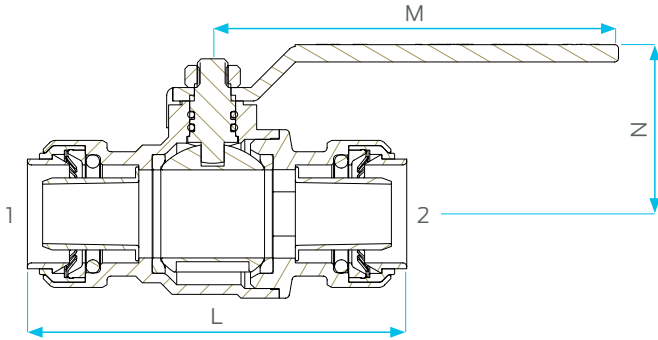

### Product Dimensions

Code	1	2	L	M	N
F670X	16 OD	16 OD	77	92	30
F672X	20 OD	20 OD	92	105	44
F674X	25 OD (DN25Cu)	25 OD (DN25Cu)	103	105	48
F680X	16 OD	RP1/2"-15	69	92	38
F682X	20 OD	RP3/4"-20	79	105	48
F684X	25 OD (DN25Cu)	RP1"-25	92	105	48

**Note:** All measurements in mm unless otherwise stated.

### Working Pressures and Temperatures

Pipe	Pressure/Temperature
PEX SDR9	Designed for operating at 2000kPa / 20°C Max operating values of 1000kPa / 70°C

### PEX Dimensions

Nominal Outside Diameter	16mm	20mm	25mm
Average Wall Thickness	2.15mm	2.45mm	3.00mm
Average Internal Diameter	11.7mm	15.2mm	19.1mm

### Installation

Installation is subject to the requirements of the applicable regulatory authority, the National Construction Code Volume Three – Plumbing Code of Australia, associated reference standards as applicable at the time and AS/NZS 3500. This product is compliant to the Lead Free requirements of the National Construction Code Volume Three. For further Scope of Use, please visit [www.rmc.com.au/resources](http://www.rmc.com.au/resources).

### Warranty

Reliance Worldwide Corporation (Aust.) Pty. Ltd. (RWC) will either replace or repair any defective goods where the defect arose as a result of manufacture within the warranty period. You may contact RWC at the phone number, address or e-mail shown below for further information or to make a claim.

Visit [www.rmc.com.au/warranty](http://www.rmc.com.au/warranty) to view the warranty statement in full and for further important information.

### Standards and Approvals



AS/NZS 4020, AS/NZS 2537.2  
AS 2492 & AS 3688, WMTS-012